

**AUXILIARY BATTERY POWER JUNCTION BLOCK AND GROUND STUDS**

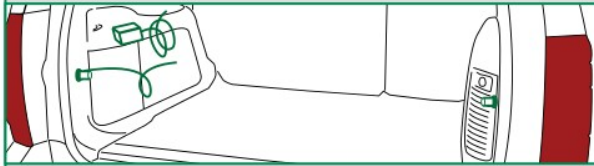

An auxiliary power junction block is located within the driver's side rear cargo area jack storage compartment. This junction block is split to provide two circuits for connection to customer-furnished equipment directly to the battery through separate 50-amp circuit breakers. These circuit breakers are located in the breaker/relay panel forward of the instrument panel glove box. A maximum load of 100-amps (1,200-watts) can be connected.

This junction block is connected to a coiled 5-foot (1.5 m) branch of rear body harness and fastened near the jack. Mounting of the junction block can be at customer-selected rear cargo area locations permitted by the branch harness length and using customer-furnished mounting hardware.

The junction block should not be attached to the interior trim plastic components without appropriate backing hardware to the mounting bolts.

Grounding studs are located on the left and right sides of the liftgate opening.

**RADIO SUPPRESSION GROUND STRAPS**

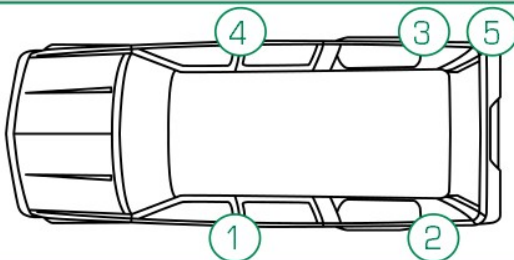

Police Package is equipped with additional grounding in the following locations:

1. Left hand front frame body mount bracket to underbody
2. Left hand rear frame body mount bracket to rear underbody
3. Right hand rear frame body mount bracket to rear underbody
4. Right hand center frame body mount bracket to center underbody
5. Exhaust pipe hanger rod to rear frame hanger

**TIRE PRESSURE MONITOR**

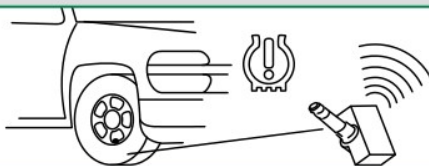

Your vehicle is equipped with a Tire Pressure Monitor (TPM) System which warns of low tire pressure. The TPM System on your Tahoe Police Package has a spare tire sensor but is not programmed to read the spare tire pressure. When the spare tire from your vehicle or an unused spare tire from another Police Package is placed in use as a road wheel, the system will not read the presence of the new TPM sensor and must be calibrated. Refer to your owner's manual for additional information on the Tire Pressure Monitor and Sensor Programming. The Special Service Package 5W4 does not have sensor in spare tire.

**WIRING PROVISIONS FOR 12-VOLT BATTERY POWER SUPPLY**

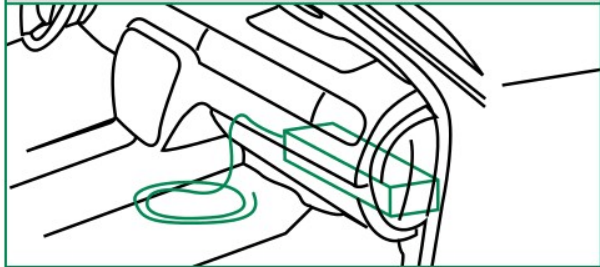

Your vehicle is equipped with wiring provisions for a 12-volt battery power supply. Refer to the following information when adding electrical system. The wiring harness is located below the instrument panel near the center of the vehicle. The following information describes the breaker and relay location.

The 12-volt battery power is supplied through two underhood mega fuses, one 125-amp and one 60-amp. This underhood power is fed to the breaker/relay center via a harness that passes through the driver side front of the dash, and routed across the instrument panel to a position forward of the glove box. The breaker/relay center is mounted to the instrument panel structure forward of the glove box. The center includes a plastic bracket, two relays, two 30-amp breakers and three 50-amp mega circuit breakers.

Two 30-amp breakers supply power from the underhood 60-amp mega fuse through the contacts of the control relays to a 12-gauge (3.0 mm<sup>2</sup>) blunt cut wires. These two blunt cut leads are part of wire coiled under the instrument panel near the center of the vehicle.

Each relay is operated by a 0.5 mm<sup>2</sup> blunt cut, light or dark blue control lead includes in a 3-foot (91 cm) loop of wire under the instrument panel.

Three 50-amp mega circuit breakers, protected by three fusible links, supply power directly from the underhood 125-amp mega fuse through three, 10-gauge (5.0 mm<sup>2</sup>) wires. Two of the wires are routed through the body harness to a split buss junction block to the left rear of the cargo area and secured near the jack and tools. This 3-foot (91 cm) of coiled wires can be accessed by removing the cup holder on the top of the trim panel. The third 10-gauge (5.0 mm<sup>2</sup>) wire is a blunt cut lead, which is part of the 3-foot (91 cm) loop of wire coiled under the instrument panel near the center of the vehicle.

An 8-gauge (8 mm<sup>2</sup>) ground lead is also provided and it is located under the front passenger sill plate. It can be accessed by removing the sill plate and pulling the loop of wire at the front of the plate, the lead is 3-feet (91 cm) long.

Blunt cut ignition control power and signal circuits are also included in the wire coiled under the instrument panel near the center of the vehicle. They include:

- A yellow, 20-gauge (0.5 mm<sup>2</sup>) circuit, HOT in ACCESSORY, RUN or RAP (Retained Accessory Power)\*
- Pink, 20-gauge (0.5 mm<sup>2</sup>) circuit, HOT in START/RUN (7-amp maximum load)
- A yellow/black, 20-gauge (0.5 mm<sup>2</sup>) transmission park signal. This circuit provides switched power when the transmission is in P (Park) and the engine is running. The circuit is at 0-volts when the transmission is in any other position, i.e., R (Reverse), N (Neutral), D (Drive) or M (Manual 6-1). NOTE that the circuit is also at 12-volts with the transmission in P (Park) and the ignition is OFF. To avoid the possibility of undesired parasitic electrical load with the ignition is OFF it is suggested that the Park/Signal circuit be isolated by routing it through the normally open contacts of a customer furnished ignition controlled relay.\*
- A dark green/white, 20-gauge (0.5 mm<sup>2</sup>) Vehicle Speed Signal (VSS) provides 4,000 pulses per mile.

**Connect Here**

The breaker and relay center is located behind and above the instrument panel storage compartment. Remove contents from the storage tray. Using the tab at the back of the compartment drop the tray down gently toward the floor. You will find the breaker/relay center above the right rear corner of the storage compartment.

\* These two circuits share a 15-amp fuse. (10-amp combined maximum load)

**NOTE: For wiring diagram see pages 28 through 31**

**WIRING DIAGRAM FOR 12-VOLT BATTERY POWER SUPPLY**

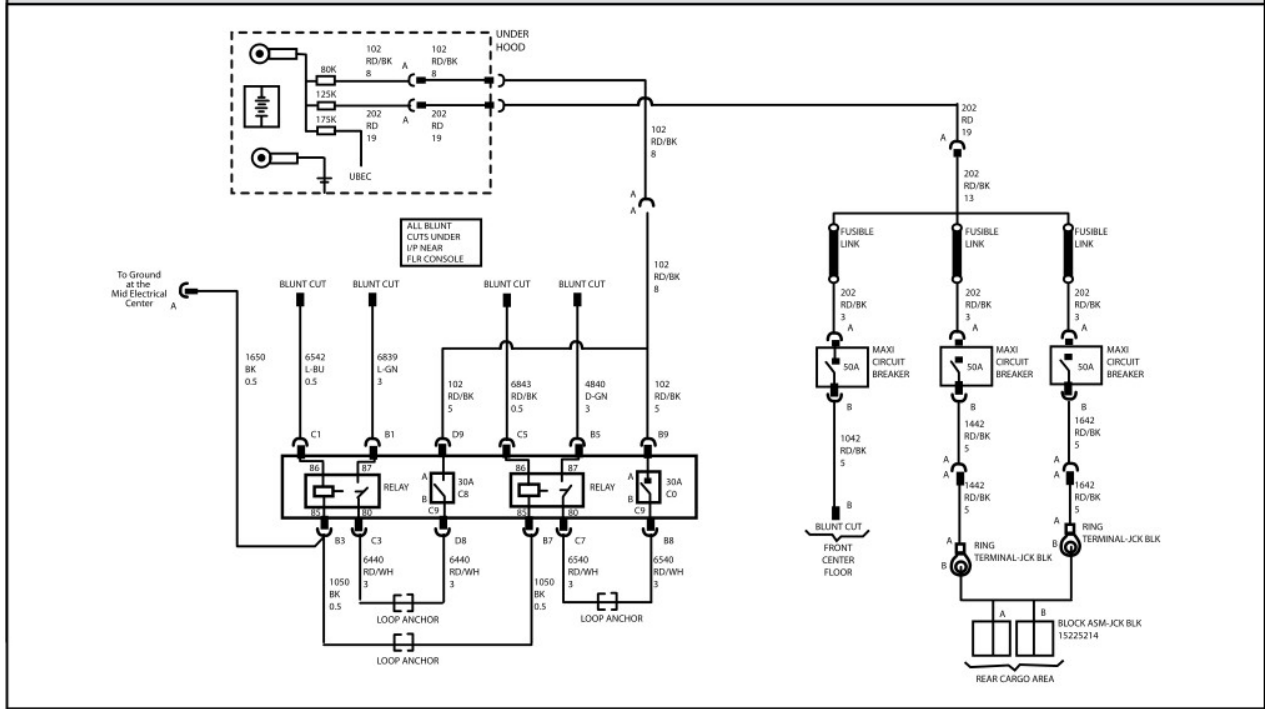

**WIRING DIAGRAM FOR CONTROLLED POWER AND SIGNAL CIRCUITS WITH 12-VOLT POWER SUPPLY**

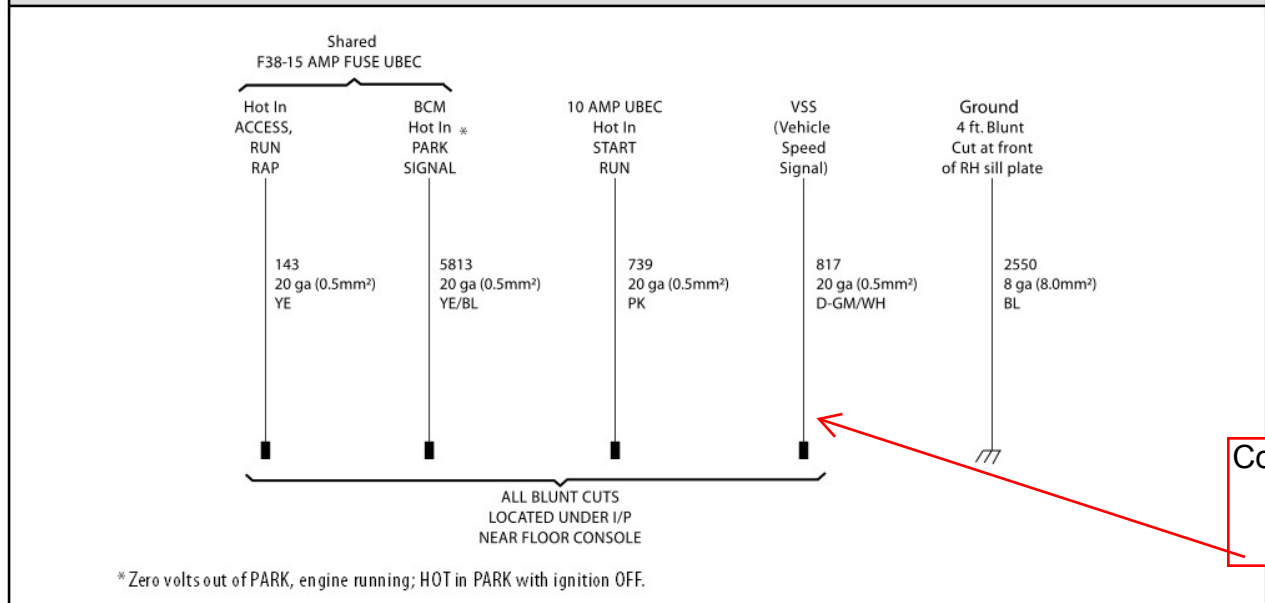

NOTE: Wiring diagrams for these options are shown in the Police Package owner's manual supplement (shipped in glove box).