

# STANDARD EQUIPMENT

## WIRING PROVISIONS FOR 12-VOLT BATTERY POWER SUPPLY

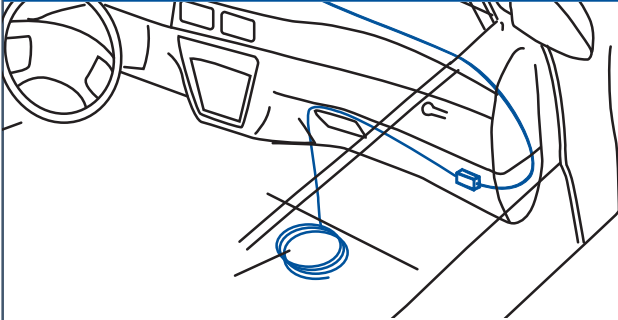

Battery power is supplied through two fusible links, one 50-amp and one 65-amp, to three circuit breakers and two control relays located in the control center above the accelerator pedal. A 50-amp circuit breaker feeds power directly from the 50-amp fusible link through a 10-gauge blunt cut wire. Two 30-amp circuit breakers supply power from the 65-amp fusible link through the contacts of the control relays to 12-gauge blunt cut wires. The blunt cut leads are part of a 5-foot coil on the floor under the instrument panel. Each relay is to be operated by an 18-gauge control lead included in the 5-foot coil under the instrument panel. An 8-gauge system ground lead is also provided in the 5-foot coil. The total current available through the 12-volt power supply is 110-amps.

Two blunt cut wires provide ignition controlled power; one is HOT when the ignition is in ACCESSORY/ON; the second is HOT when the ignition is in START/ON.

A third blunt cut wire from the body control module provides a park-enable signal. When the transmission is in PARK, zero volts (not ground) are present and 12-volts are present when the transmission is in any other position. The circuit is designed to operate a single customer-furnished relay.

A fourth blunt cut wire provides the Vehicle Speed Signal (VSS).

**NOTE:** See wiring diagrams section for description

Connect Here

## KEYLOCK CYLINDER – TRUNK LID

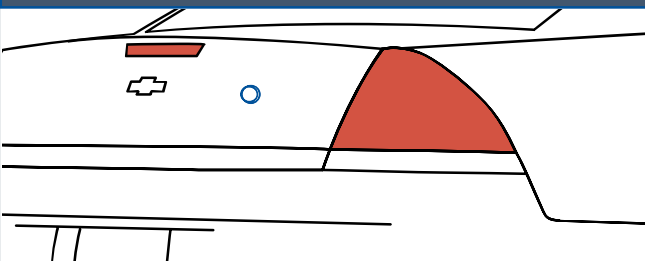

If your vehicle is equipped with the Theft Deterrent System (option UA6), an audible alarm will occur when the key is used to open the trunk instead of the remote keyless entry (transmitter). See your dealer/retailer to disable the audible alarm.

## AUXILIARY BATTERY POWER JUNCTION BLOCK IN TRUNK

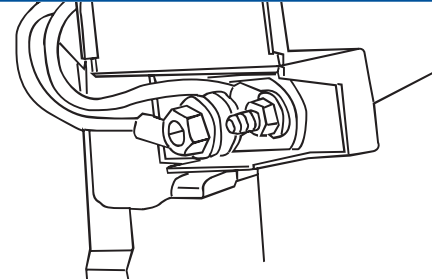

The auxiliary battery power junction block is mounted in the trunk of your Impala police vehicle. It is located on the passenger side support strut behind the rear wheel housing. This junction block is split to provide two circuits and can be used to connect customer-furnished equipment directly to the battery through 8-gauge (8 mm<sup>2</sup>) body wiring and fusible links. A maximum of 100-amps (1200-watts) can be connected. Torque the connections to the studs to 11 lb.-ft. (15 N-m). It is fed by two fusible links of 50-amps each.

**NOTE:** See wiring diagrams section for description

## TRUNK GROUND STUD

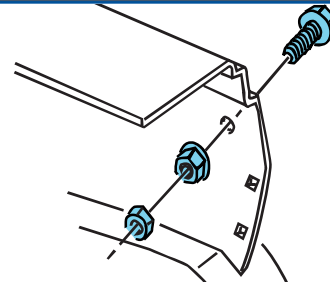

A 10 mm ground stud can be found in the trunk on the passenger's side of the vehicle. The stud is located above the trunk auxiliary junction block. See "Trunk Auxiliary Battery Power Junction Block" for more information on location. A 10 mm flanged hex nut grounds the 10 mm bolt to the vehicle. Recommended torque for the flanged nut is 26 lb.-ft. (35 N-m), plus or minus 4 lb.-ft. (5 N-m). A 10 mm hex nut is provided for customer ground termination. Recommended torque for the terminal connection nut is 7.3 lb.-ft. (10 N-m), plus or minus 1 lb.-ft. (1.3 N-m).

## MAT – TRUNK



Heavy-duty mat covers floor.

# WIRING

## WIRING DIAGRAM FOR 12-VOLT BATTERY POWER SUPPLY

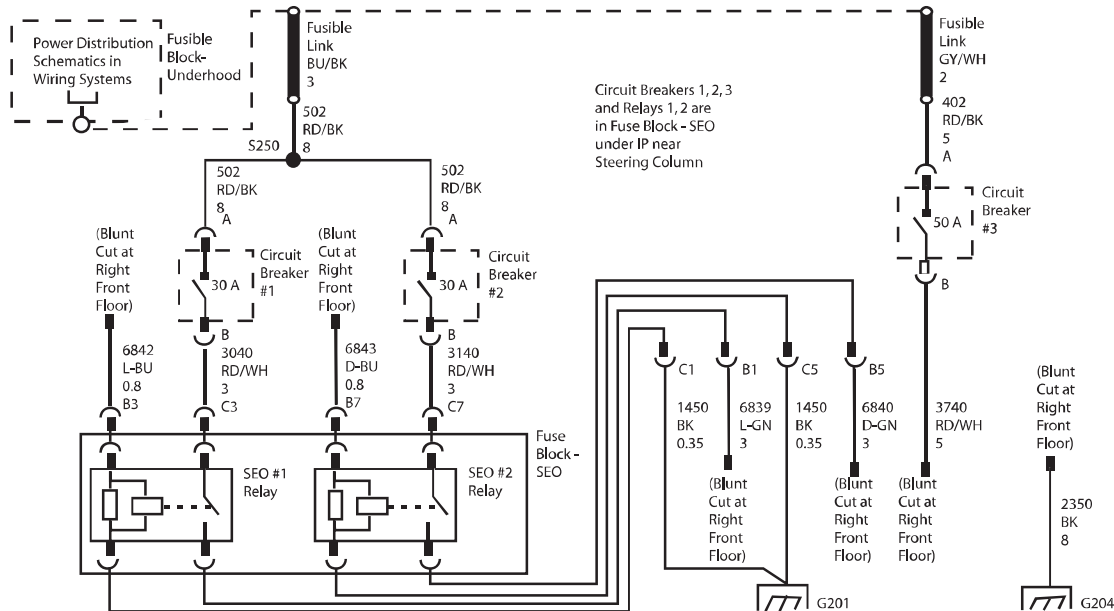

Circuit Breakers 1, 2, 3 and Relays 1, 2 are in Fuse Block - SEO under IP near Steering Column

Battery power is supplied through two fusible links, one 50-amp and one 65-amp, to three circuit breakers and two control relays located in the relay center above the accelerator pedal. A 50-amp circuit breaker feeds power directly from the 50-amp fusible link through a 10-gauge (5.0 mm<sup>2</sup>) blunt cut wire. Two 30-amp circuit breakers supply power from the 65-amp fusible link through the contacts of the control relays to 12-gauge (3.0 mm<sup>2</sup>) blunt cut wires. The blunt cut leads are part of a 5-foot (1.5 m) loop of wire coiled under the

instrument panel in the passenger's side footwell. Each relay is operated by an 18-gauge (0.8 mm<sup>2</sup>) blunt cut, light or dark blue control lead included in the 5-foot (1.5 m) coil under the instrument panel. An 8-gauge (8.0 mm<sup>2</sup>) ground lead is also provided in the 5-foot (1.5 m) coil. The total current available through the 12-volt power supply is 110-amps (1320-watts).

## WIRING DIAGRAM FOR CONTROLLED POWER AND SIGNAL CIRCUITS WITH 12-VOLT POWER SUPPLY

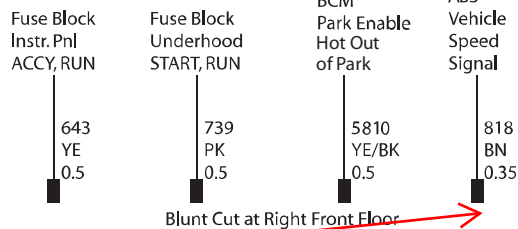

Blunt cut ignition controlled power and signal circuits are also included in the 5-foot (1.5 m) loop in the front passenger footwell. The spotlight fuses are located in the passenger's side underhood fuse block. See "Fuses and Circuit Breakers" in your owner's manual index for more information.

- A yellow, 20-gauge (0.5 mm<sup>2</sup>) 10-amp fused circuit, HOT in ACCESSORY, RUN or RAP (Retained Accessory Power) Fuse "RAP" is in the end of the instrument panel.
- A pink, 20-gauge (0.5 mm<sup>2</sup>) 10-amp fused circuit, HOT in START/RUN. Fuse "PWR Drop/CRNK" is in the underhood fuse block.
- A yellow/black, 20-gauge transaxle park signal from the Body Control Module (BCM). This circuit provides switched power (12-volts) when the transmission is not in PARK (P) and the engine is running. The electrical load attached to the park circuit must not exceed 0.5-amps (one relay coil).
- A brown, 22-gauge (0.35 mm<sup>2</sup>) vehicle speed signal (4,000 pulses/mile) from the ABS module. Connect only high impedance load.

Connect here

## WIRING DIAGRAM FOR AUXILIARY BATTERY POWER JUNCTION BLOCK

